

POPCORNBEEKERS FORMAAT A - MAAT S / POPCORNBECHER MODELL A - FORMAT S / POPCORN BOXES SHAPE A - SIZE S

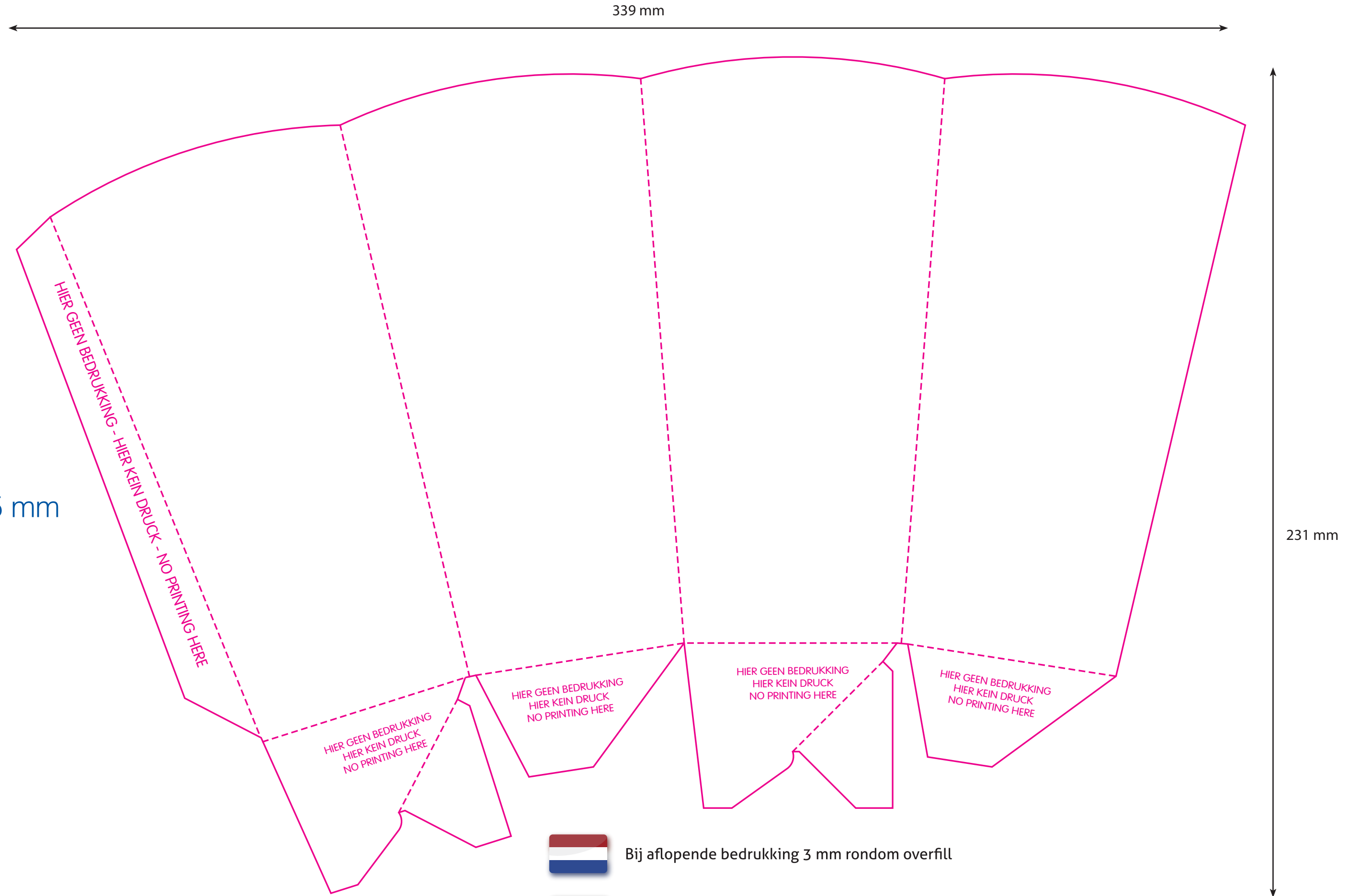

Bij aflopende bedrukking 3 mm rondom overfill

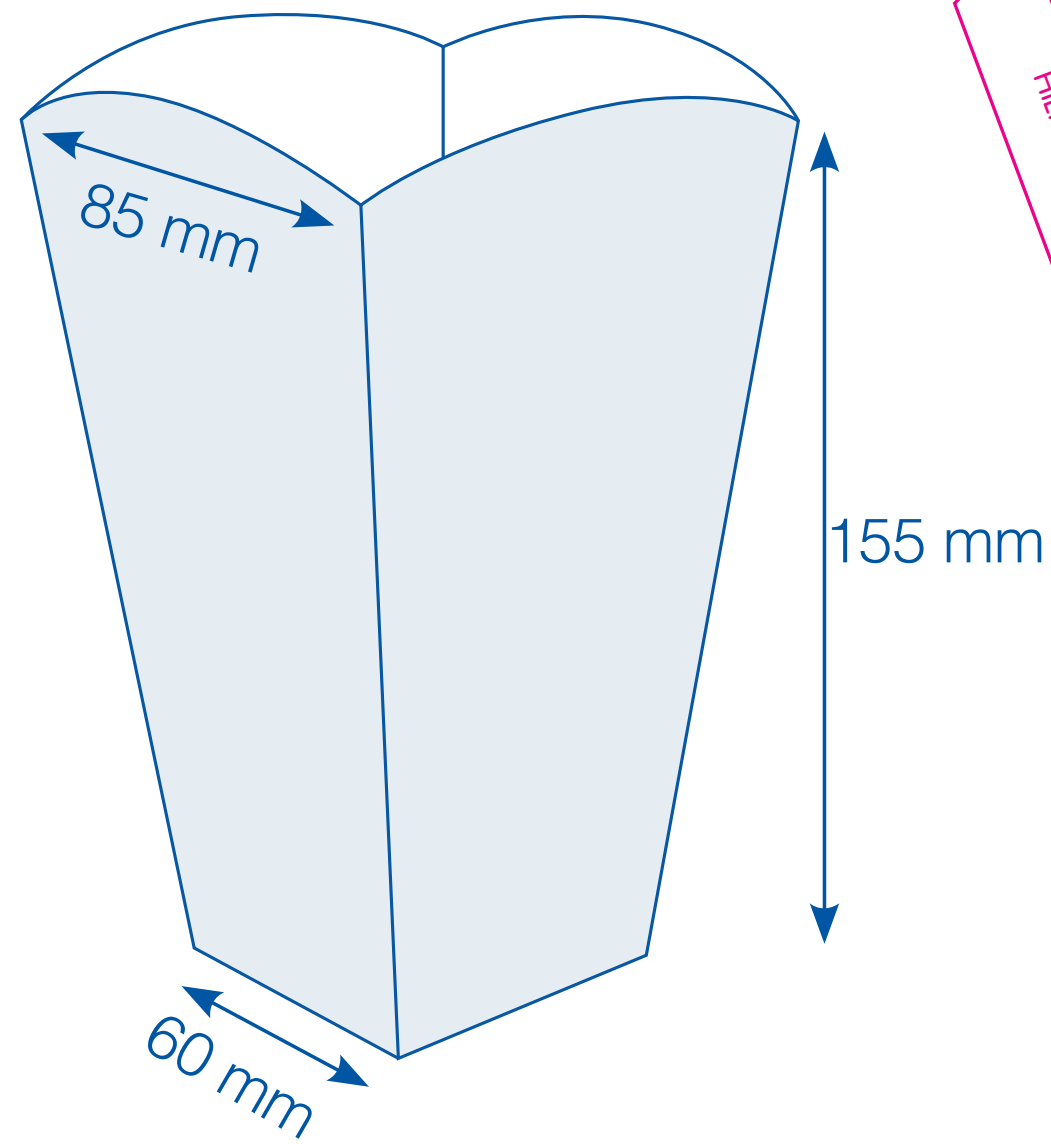

Bei randabfallendem Druck, Vorlage 3 mm größer anlegen



If bled edge printed artwork should be 3 mm overfill

POPCORNBEEKERS VORM B - FORMAAT S / POPCORNBECHER MODELL B - FORMAT S / POPCORN BOXES SHAPE B - SIZE S

